

Technical Specification UTS 750

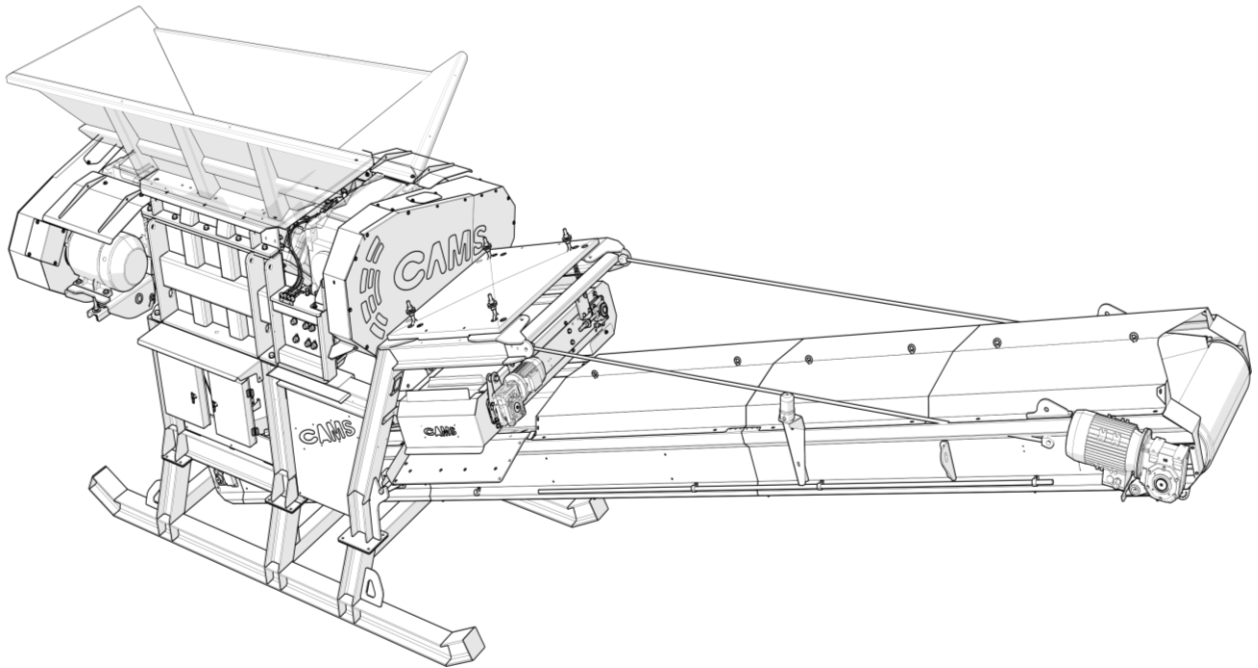

ADVANTAGES

High capacity up to 80 t/h

Low air pollution

Low noise pollution

No vibrations

Low wear costs and maintenance

Changing all the cutting tools on the shafts only takes a few hours.

Hydraulic setting adjustment

All specifications subject to change without prior notice.



CAMS s.r.l.
VIA Giulio Golini, 301 40024- Castel San Pietro Terme (BO)- Tel. 0516946611
Cod. Fisc. e Part. IVA 02146431206- R.E.A. n° 416377- Cap. Soc. 93.000 euro Int. Vers.

FEATURES

Shredder

- Type of Shredder FTR 750
- Feed opening mm 750x900
- Max feed size mm 400x350x300
- Electric motor kW 22 (11+11)
- Rotors speed rpm 10
- Max Capacity t/h 80
- Weight Kg 5.500
- V belts and pulleys
- Chuteworks

Feeding Hopper

- Capacity : m³ 1,50
- Length : m 2,30
- Width : m 1,70
- Extensions: optional

Main Conveyor TNL 600x5,00 m

- Length m 5,00
- Belt width mm 600
- Belt speed m/s 1,4
- Capacity t/h 120
- Electric moto-reducer kW 4
- Height discharge m 2,00

Overband Magnet

- Conveyor Length m 1,30
- Belt width mm 500
- Magnet mm 720x460
- Power 250 Gauss at 200 mm
- Electric moto-reducer kW 1,1

Electrical control panel

- Electrical cabinet with interlocking and cabling to motors
- PLC controls
- Incoming cables to control cabinet Excluded
- Volt 400 – 50 Hz

Chassis

Heavy duty fabricated I section of welded construction

All specifications subject to change without prior notice.



CAMS s.r.l.
VIA Giulio Golini, 301 40024- Castel San Pietro Terme (BO)- Tel. 0516946611
Cod. Fisc. e Part. IVA 02146431206- R.E.A. n° 416377- Cap. Soc. 93.000 euro Int. Vers.

Transport Dimension:

- Width m 2,40
- Height m 2,50
- Length m 7,00
- Weight Kg 8.000

Work Dimension

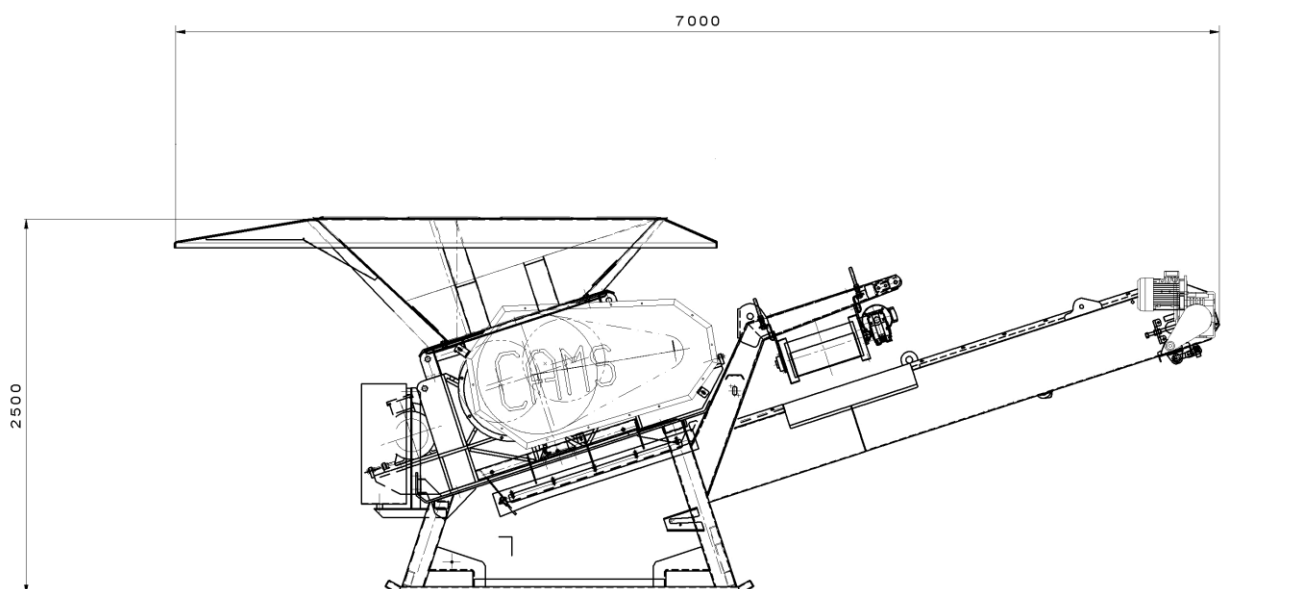

All specifications subject to change without prior notice.



CAMS s.r.l.
VIA Giulio Golini, 301 40024- Castel San Pietro Terme (BO)- Tel. 0516946611
Cod. Fisc. e Part. IVA 02146431206- R.E.A. n° 416377- Cap. Soc. 93.000 euro Int. Vers.