

UTM1500-3



Technical Specification

All the specifications reported in this document may be subject to change without prior notice.

CAMS s.r.l.

**VIA Giulio Golini, 301 40024- Castel San Pietro Terme (BO)- Tel. 0516946611
Cod. Fisc. e Part. IVA 02146431206- R.E.A. n° 416377- Cap. Soc. 93.000 euro Int. Vers.**



Features:

Width(transport):	m 2,50
Length (transport):	m 10,55
Height (transport):	m 3.00
Shredder Type:	FTR 1500
Weight:	Kg 22.500
Genset:	Diesel IVECO N67 212 kW at 1500 rpm Alternator 210 KVA

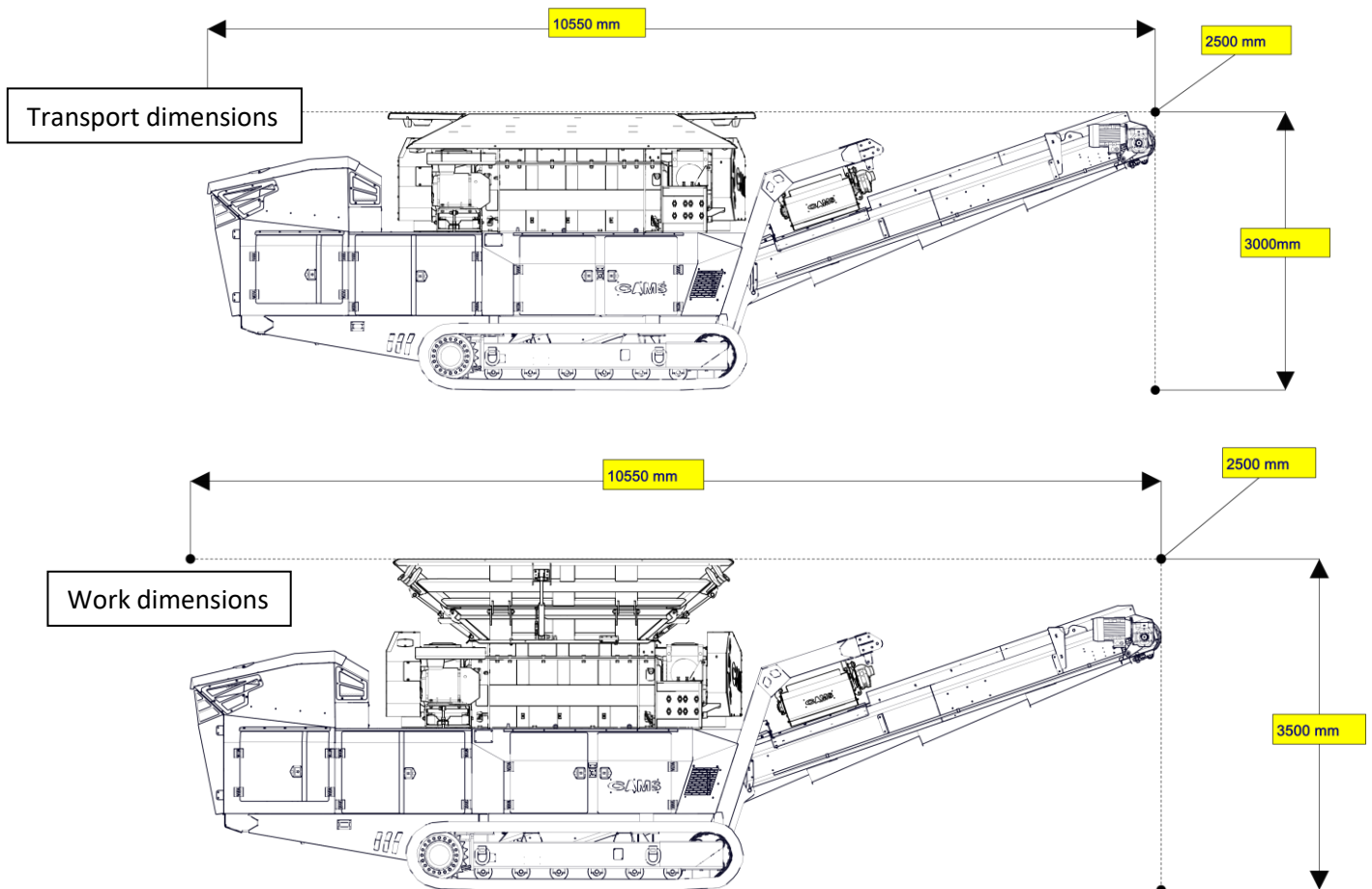

Advantages:

- High productivity up to 180 t / h
- Quick installation
- Remote control with cable.
- Single genset in order to minimize fuel consumption
- Engine Electrical, to optimize performance in order to reduce fuel consumption
- Engine Electrical, to ensure a consistent performance of screening regardless of the environmental conditions of work.
- Optional radio control wireless.
- Don't produce noise and air pollution
- Possibility to distribute electricity to the jobsite

All the specifications reported in this document may be subject to change without prior notice.

CAMS s.r.l.

**VIA Giulio Golini, 301 40024- Castel San Pietro Terme (BO)- Tel. 0516946611
Cod. Fisc. e Part. IVA 02146431206- R.E.A. n° 416377- Cap. Soc. 93.000 euro Int. Vers.**



Feeding Hopper:

Length: m 3.50
Width m 2.00
Capacity: m³ 3.80
Hydraulic Feed hopper extensions

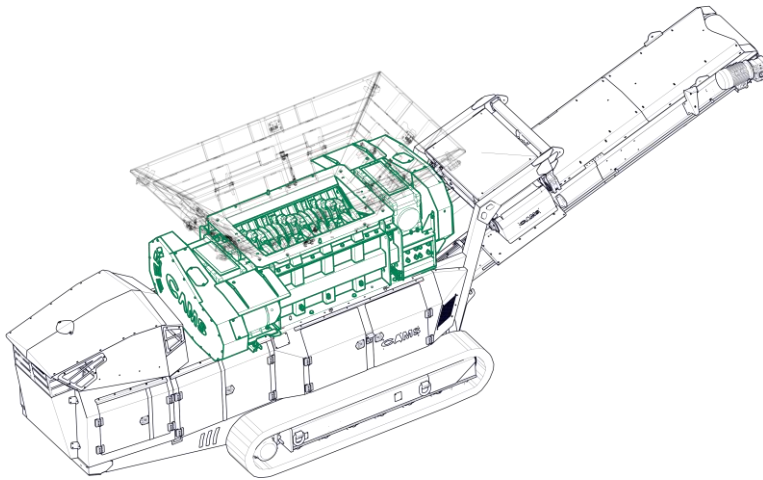
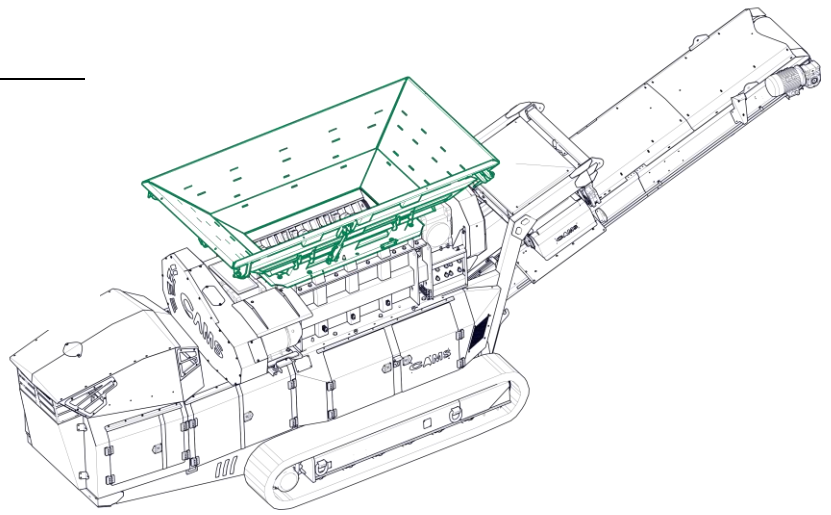

Shredder:

Type of Shredder: FTR 1500
Feed opening: mm 1500x900
Rotor Knives: pcs 30
Rotor Knives width: mm 50
Electric motor: kW 44 (22+22)
Rotors speed: rpm 10

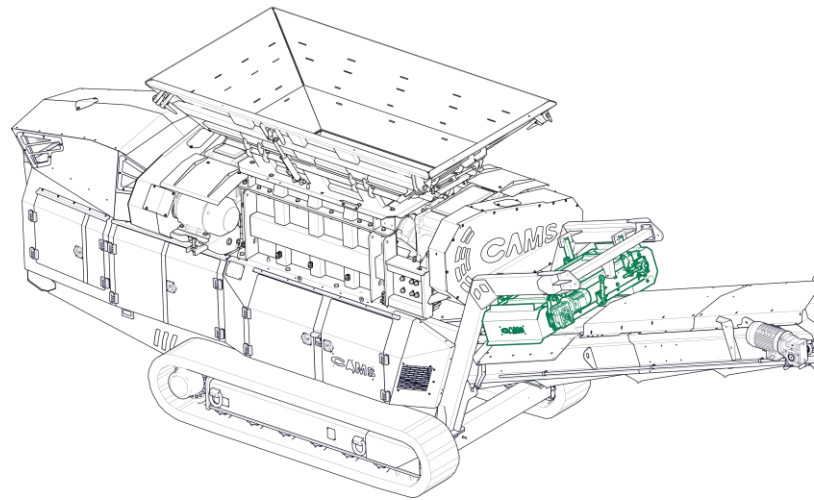

Overbelt Magnet:

Belt width: mm 650
Conveyor length: mm 1.660
Electric moto-reducer kW 1.5
Power: 420 Gauss at 200 mm

Main Conveyor:

Belt width: mm 800
Electric moto-reducer: kW 5.5
Stockpile Height: m 3.00
Dust reduction

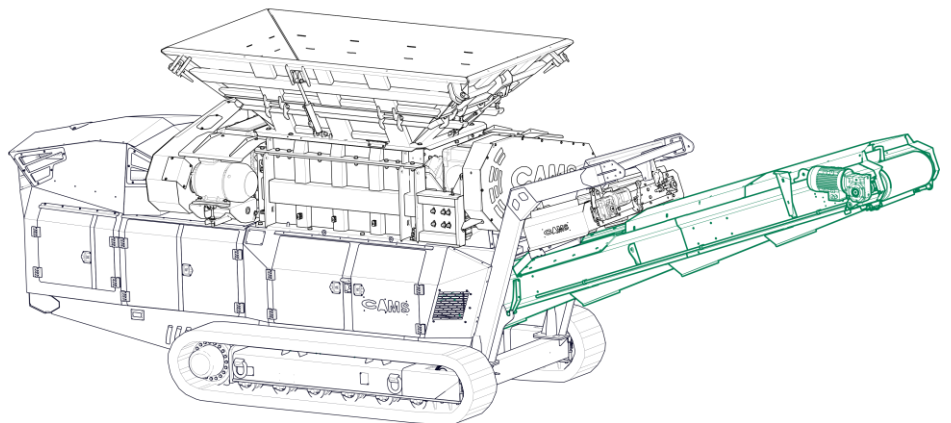

All the specifications reported in this document may be subject to change without prior notice.

CAMS s.r.l.

**VIA Giulio Golini, 301 40024- Castel San Pietro Terme (BO)- Tel. 0516946611
Cod. Fisc. e Part. IVA 02146431206- R.E.A. n° 416377- Cap. Soc. 93.000 euro Int. Vers.**



Track Data:

Track length: mm 3790
Track width: mm 400
Hydraulic Motor: bosch Rexroth 28/60 cc
Gearbox: Trasmital
Speed: 0,3÷0,6 Km/h
Control: Remote handset - Dual Speed

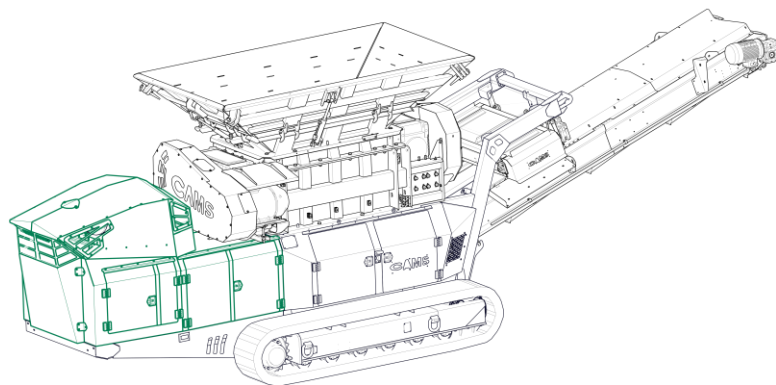
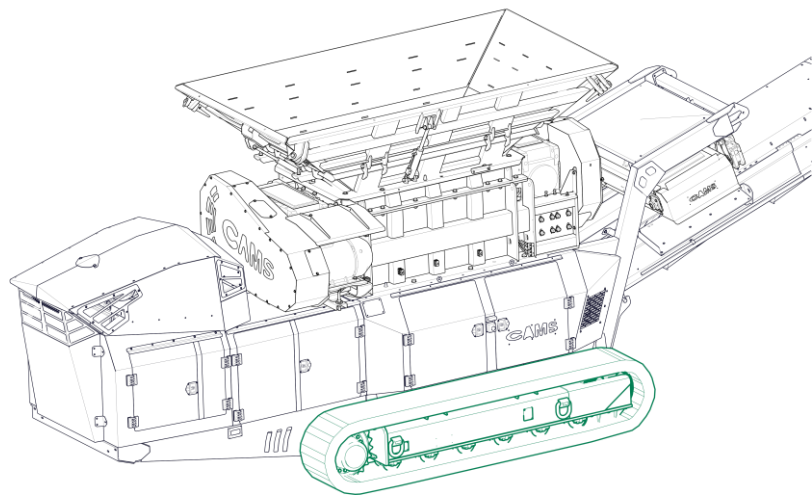

Genset:

Diesel Engine: IVECO N67 212 kW at 1500 rpm
Alternator: Marelli 300 KVA

Tank capacities:

Hydraulic: l 85
Fuel: l 170

All the specifications reported in this document may be subject to change without prior notice.

CAMS s.r.l.

**VIA Giulio Golini, 301 40024- Castel San Pietro Terme (BO)- Tel. 0516946611
Cod. Fisc. e Part. IVA 02146431206- R.E.A. n° 416377- Cap. Soc. 93.000 euro Int. Vers.**



UTM 1500-3 - AT WORK



UTM 1500-3 - SHIPMENT



All the specifications reported in this document may be subject to change without prior notice.

CAMS s.r.l.

**VIA Giulio Golini, 301 40024- Castel San Pietro Terme (BO)- Tel. 0516946611
Cod. Fisc. e Part. IVA 02146431206- R.E.A. n° 416377- Cap. Soc. 93.000 euro Int. Vers.**

