

Centauro 100/32

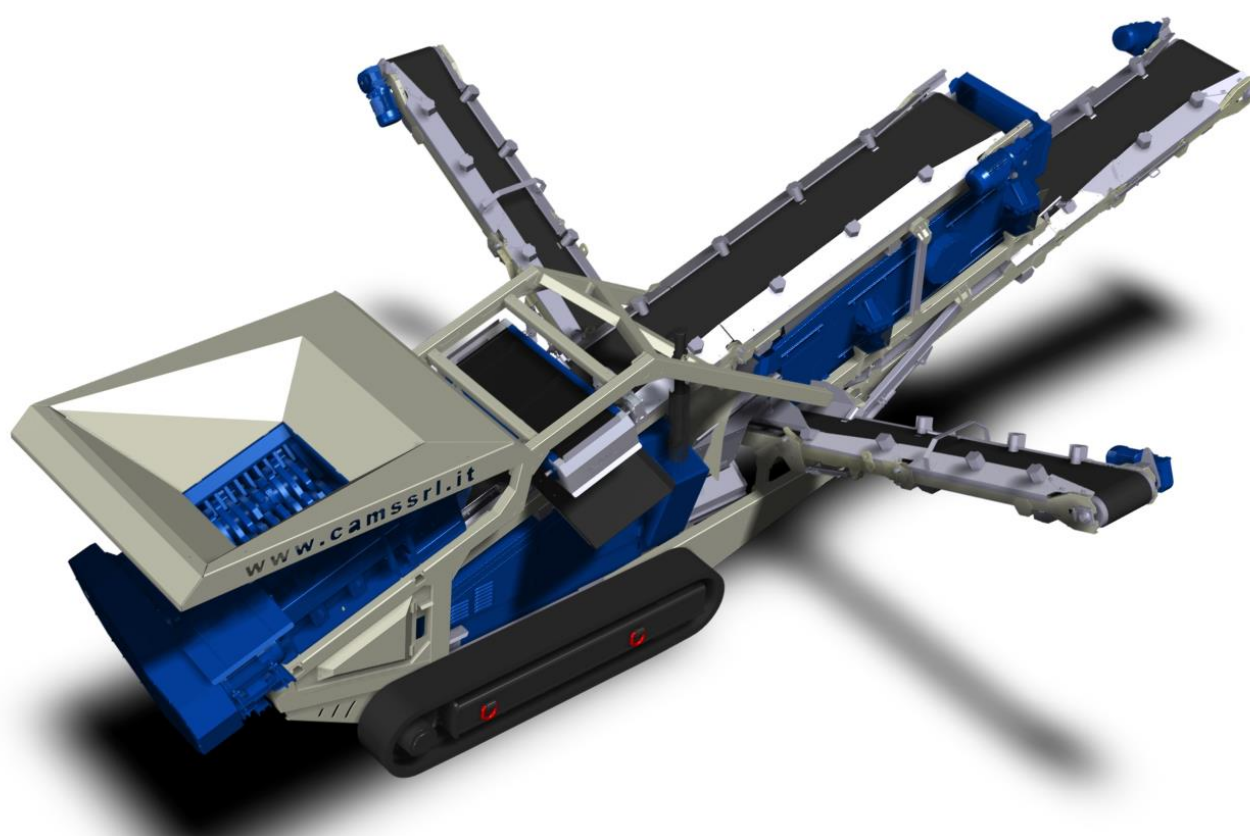

Technical Specification

All specifications subject to change without prior notice

CAMS S.r.l.

**VIA Giulio Golini, 301 40024- Castel San Pietro Terme (BO)- Tel. 0516946611
Cod. Fisc. e Part. IVA 02146431206- R.E.A. n° 416377- Cap. Soc. 93.000 euro Int. Vers.**



Features:

Width(transport):	m 2,55
Length (transport):	m 11,2
Height (transport):	m 3.1
Shredder Type:	FTR 1000
Screenunit:	m 3.20x1.00 double deck
Weight:	Kg 24.000
Genset	Diesel JCB 448 121KW at 1500 rpm Alternator130KVA

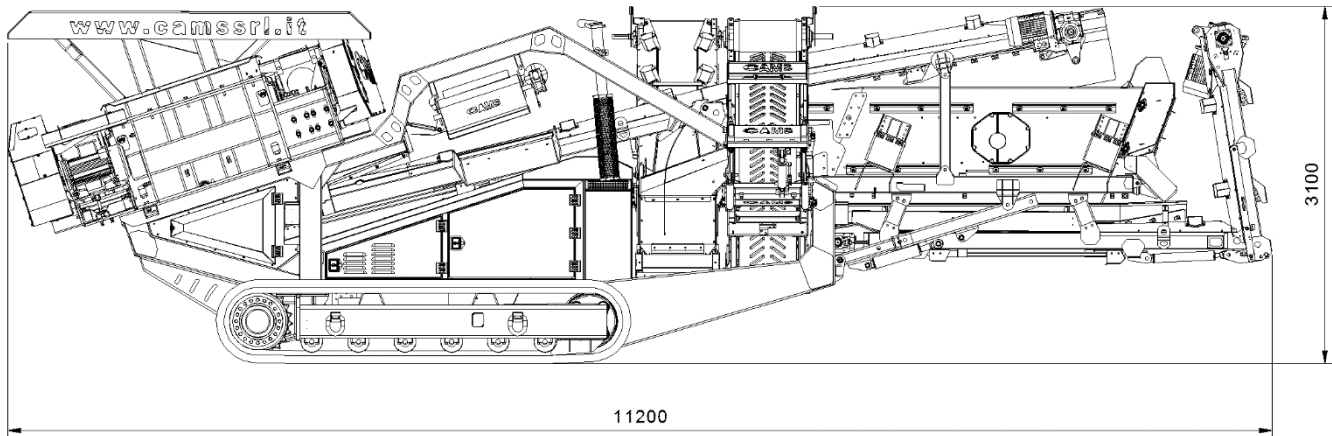

Advantages:

- High productivity up to 120 t / h
- Quick installation
- Remote control with cable.
- Single genset in order to minimize fuel consumption
- Engine Electrical, to optimize performance in order to reduce fuel consumption
- Engine Electrical, to ensure a consistent performance of screening regardless of the environmental conditions of work.
- Big distance between the two screening decks (600mm) allows an easy maintainability.
- Optional to change speed on all the conveyors.
- Optional radio control wireless.
- Don't produce noise and air pollution
- Possibility to distribute electricity to the jobsite

Feeding Hopper:

Length:	m 3.00
Width	m 2.00
Capacity:	m ³ 3.00
Hydraulic Feed hopper extensions optional extra	

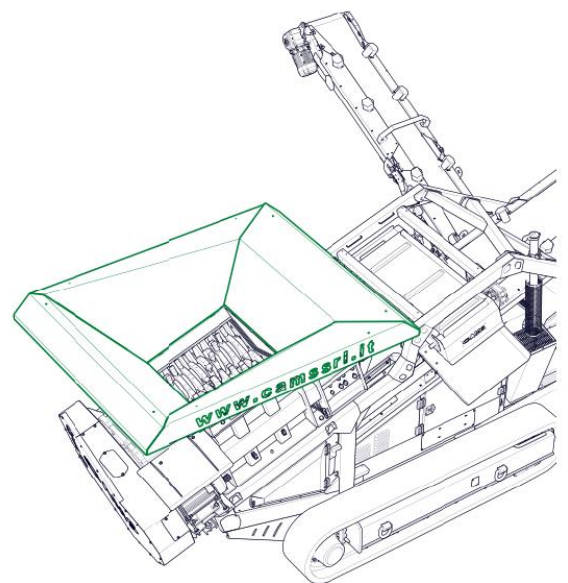

All specifications subject to change without prior notice

CAMS s.r.l.

**VIA Giulio Golini, 301 40024- Castel San Pietro Terme (BO)- Tel. 0516946611
Cod. Fisc. e Part. IVA 02146431206- R.E.A. n° 416377- Cap. Soc. 93.000 euro Int. Vers.**



Shredder:

Type of Shredder: FTR 1000
Feed opening: mm 1000x900
Rotor Knives: pcs 18
Rotor Knives width: mm 50
Electric motor: kW 30 (15+15)
Rotors speed: rpm 10

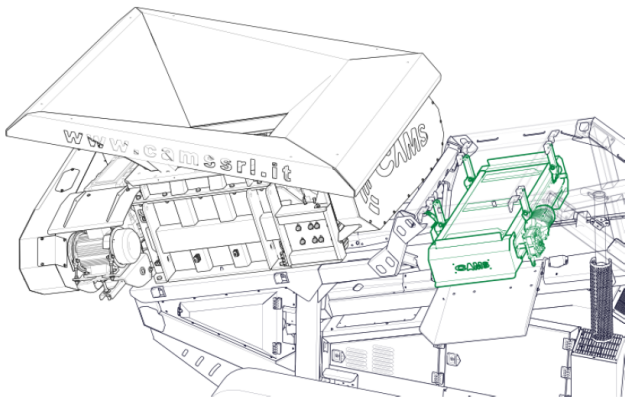
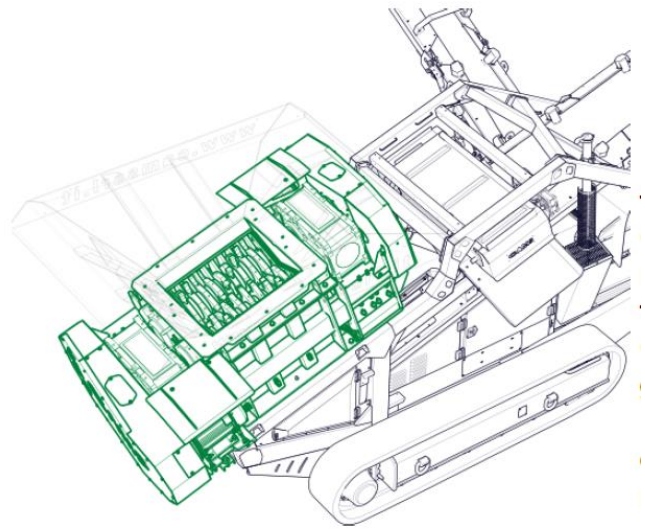

Overbelt Magnet:

Belt width: mm 650
Conveyor length: mm 1.660
Electric moto-reducer kW 1.5
Power: 420 Gauss at 200 mm

Screenunit:

Screen Area: m 3.20x1.00
Deck: n° 2
Electric motor: kW 4

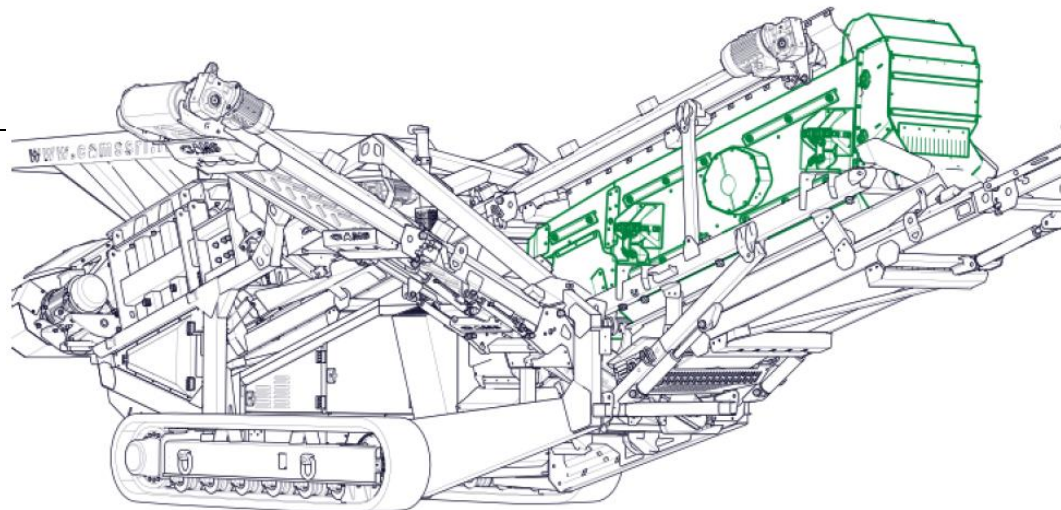

All specifications subject to change without prior notice



CAMS s.r.l.
VIA Giulio Golini, 301 40024- Castel San Pietro Terme (BO)- Tel. 0516946611
Cod. Fisc. e Part. IVA 02146431206- R.E.A. n° 416377- Cap. Soc. 93.000 euro Int. Vers.

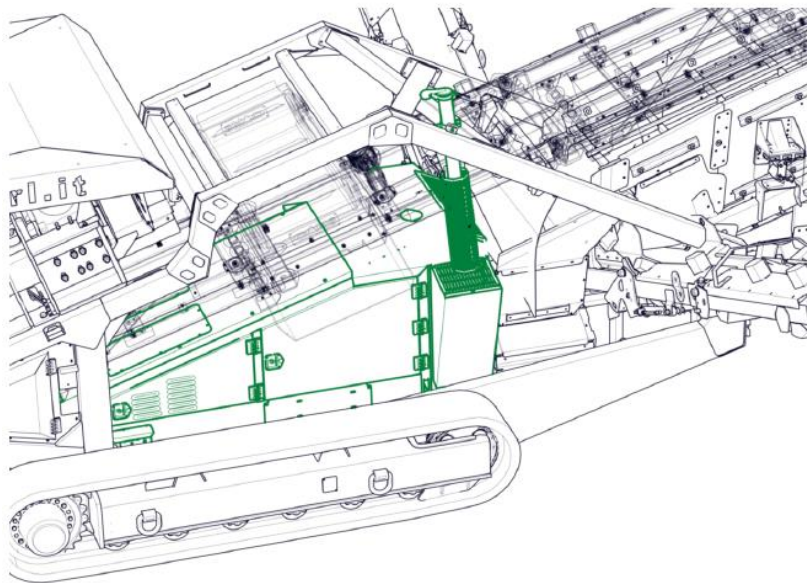

Genset:

Diesel Engine: JCB 448 121 kW a 1500 rpm
 Alternator: M.E.C.C. ALTE 130 kVA

Tank capacities:

Hydraulic: 185
 Fuel: 1170

Side Conveyors:

Belt width: mm 500
 Stockpile height: m 2.70÷ 3.30
 Electric moto-reducer: kW 4
 Hydraulically folding
 Dust reduction

Main Conveyor:

Belt width: mm 800
 Electric moto-reducer: kW 5.5
 Dust reduction

Tail Conveyor:

Belt width: mm 800
 Stockpile height: m 2.70÷ 3.30
 Electric moto-reducer: kW 4
 Hydraulically folding
 Dust reduction

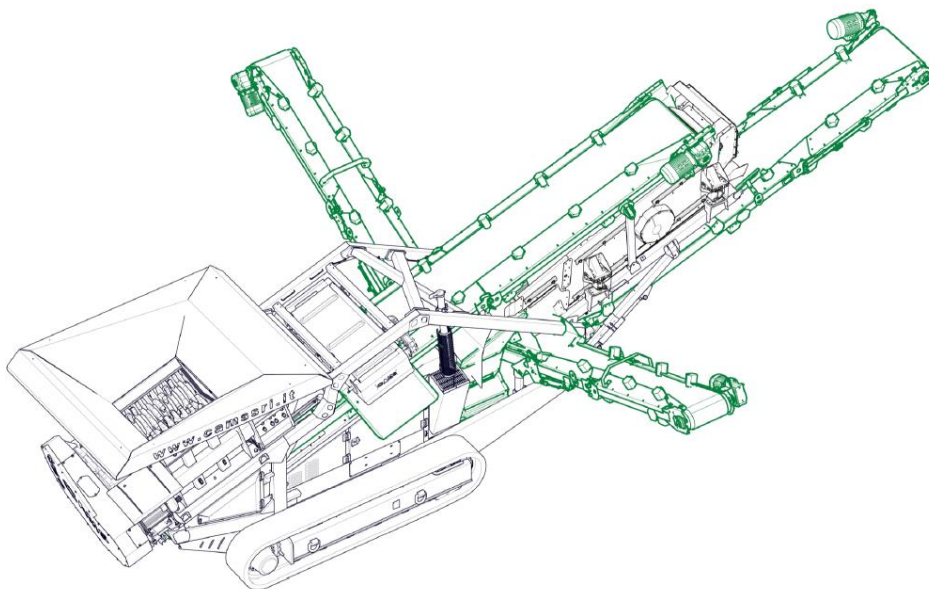

Track Data:

Track length: mm 2920
 Track width: mm 400
 Hydraulic Motor: bosch Rexroth 28/60 cc
 Gearbox: Trasmital
 Speed: 0,4÷0,8 Km/h
 Control: Remote handset - Dual Speed

All specifications subject to change without prior notice

CAMS s.r.l.

VIA Giulio Golini, 301 40024- Castel San Pietro Terme (BO)- Tel. 0516946611
 Cod. Fisc. e Part. IVA 02146431206- R.E.A. n° 416377- Cap. Soc. 93.000 euro Int. Vers.



OPTIONAL EXTRAS

Hydraulic Fingers:

Number of fingers n° 5
Number of Knife: n° 2/pcs.
Number of Teeth: n° 2/pcs.

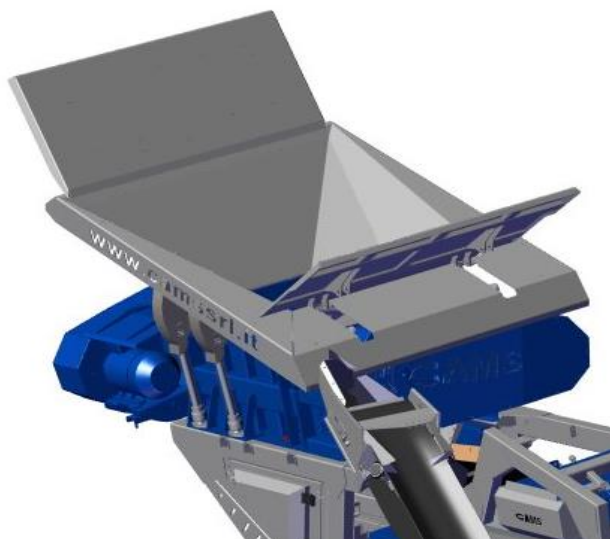
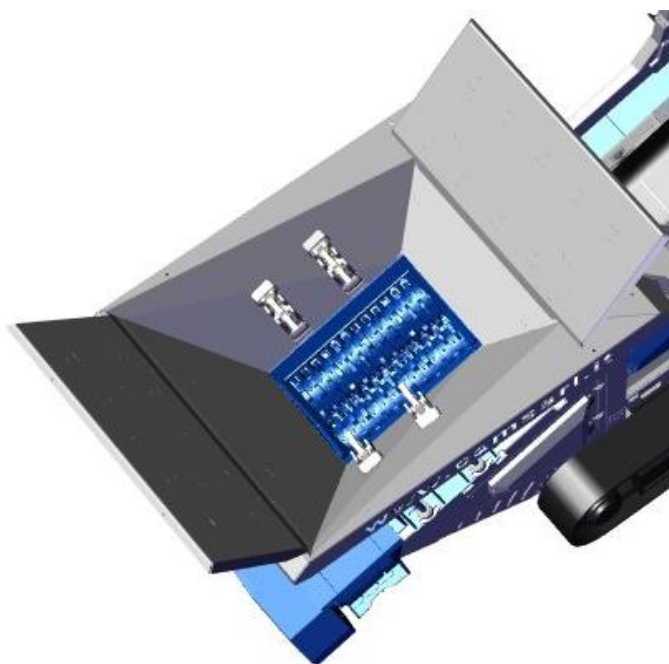

Hydraulic Feed Hopper extensions:

Height: mm 800
Lenght mm 750

Hydraulic setting Adjustment:

Hydraulic Jack: N° 2
Number of components N° 3

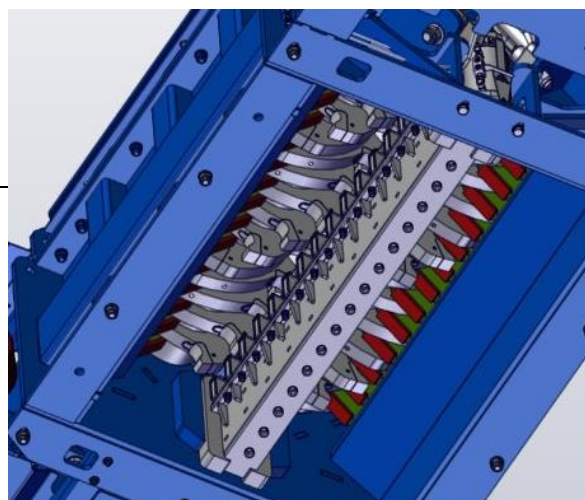

All specifications subject to change without prior notice

CAMS s.r.l.

VIA Giulio Golini, 301 40024- Castel San Pietro Terme (BO)- Tel. 0516946611
Cod. Fisc. e Part. IVA 02146431206- R.E.A. n° 416377- Cap. Soc. 93.000 euro Int. Vers.



CENTAURO 100/32 AT WORK



CENTAURO 100/32 FOR SHIPPING



All specifications subject to change without prior notice

CAMS s.r.l.

**VIA Giulio Golini, 301 40024- Castel San Pietro Terme (BO)- Tel. 0516946611
Cod. Fisc. e Part. IVA 02146431206- R.E.A. n° 416377- Cap. Soc. 93.000 euro Int. Vers.**

