

Centauro L 120/56 APR



Technical Specification

All specifications subject to change without prior notice

CAMS s.r.l.

**VIA Giulio Golini, 301 40024- Castel San Pietro Terme (BO)- Tel. 0516946611
Cod. Fisc. e Part. IVA 02146431206- R.E.A. n° 416377- Cap. Soc. 93.000 euro Int. Vers.**



Features:

Width(transport):	m 2,55
Length (transport):	m 13,00
Height (transport):	m 3.10
Shredder Type:	FTR 1200
Screenunit:	CVV 056/2 double deck
Weight:	Kg 30.000 (Without Optional)
Weight:	Kg 35.500 (Full Optional)
Genset	Diesel IVECO C87 256 kW at 1500 rpm Alternator400 kVA

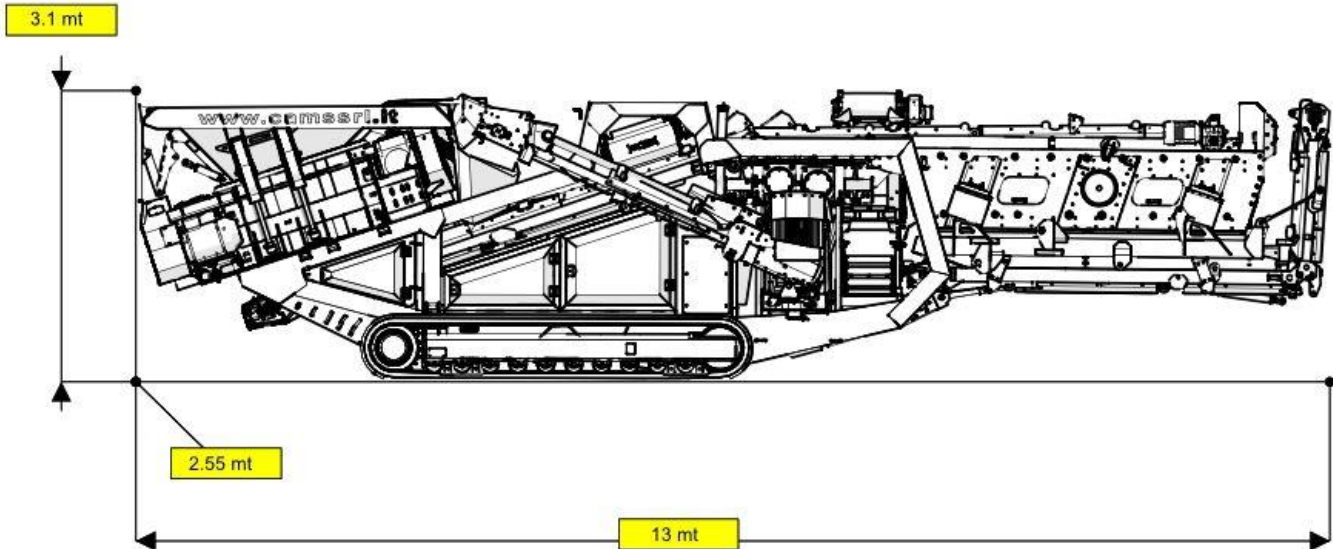

Advantages:

- High productivity up to 180 t / h
- Quick installation
- Remote control with cable.
- Single genset in order to minimize fuel consumption
- Engine Electrical, to optimize performance in order to reduce fuel consumption
- Engine Electrical, to ensure a consistent performance of screening regardless of the environmental conditions of work.
- Big distance between the two screening decks (600mm) allows an easy maintainability.
- Optional to change speed on all the conveyors.
- Optional radio control wireless.
- Don't produce noise and air pollution
- Possibility to distribute electricity to the jobsite

Feeding Hopper:

Length:	m 2.50
Width	m 2.30
Capacity:	m ³ 3.00

Hydraulic Feed hopper extensions optional extra

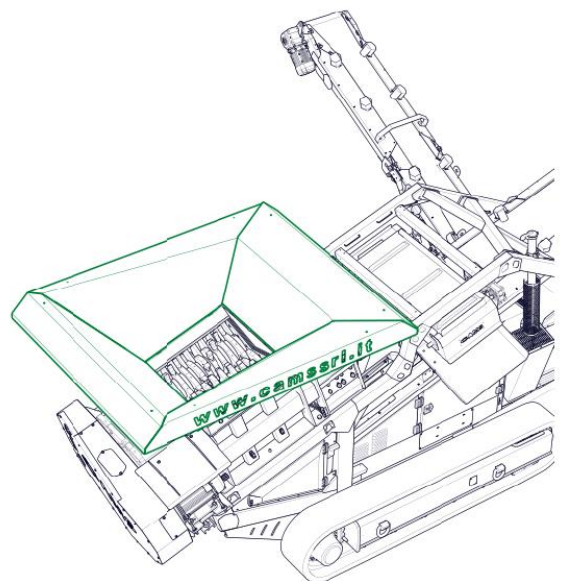

All specifications subject to change without prior notice

CAMS s.r.l.

VIA Giulio Golini, 301 40024- Castel San Pietro Terme (BO)- Tel. 0516946611
Cod. Fisc. e Part. IVA 02146431206- R.E.A. n° 416377- Cap. Soc. 93.000 euro Int. Vers.



Shredder (C&D):

Type of Shredder: FTR 1200
Feed opening: mm 1200x900
Rotor Knives: pcs 24
Rotor Knives width: mm 50
Electric motors: kW 60 (30+30)
Rotors speed: rpm 10

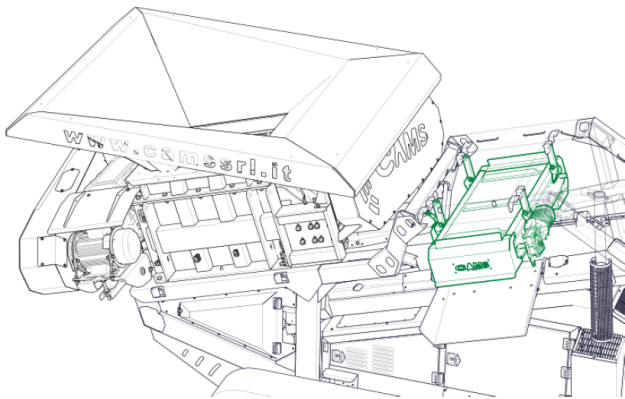
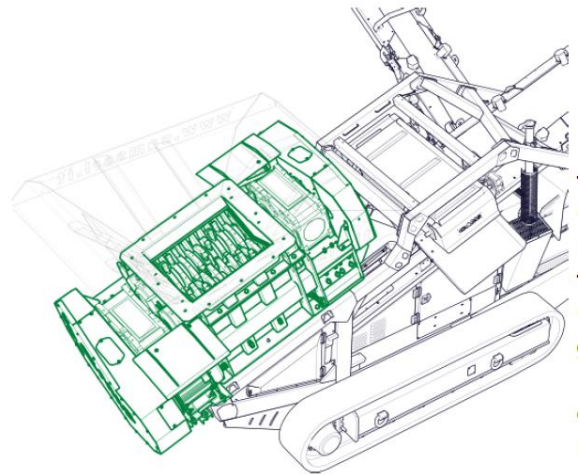

Overbelt Magnet:

Belt width: mm 650
Conveyor length: mm 1.660
Electric moto-reducer kW 1.5
Power: 420 Gauss at 200 mm

Screenunit:

Screen Area: m 4.25x1.30
Deck: n° 2
Electric motors: kW 8 (4+4)

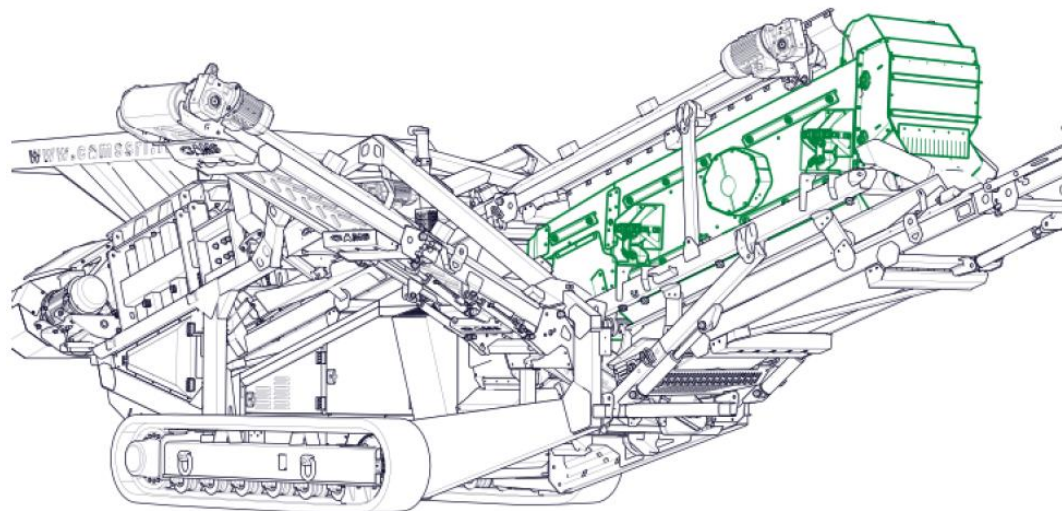

All specifications subject to change without prior notice



CAMS s.r.l.
VIA Giulio Golini, 301 40024- Castel San Pietro Terme (BO)- Tel. 0516946611
Cod. Fisc. e Part. IVA 02146431206- R.E.A. n° 416377- Cap. Soc. 93.000 euro Int. Vers.

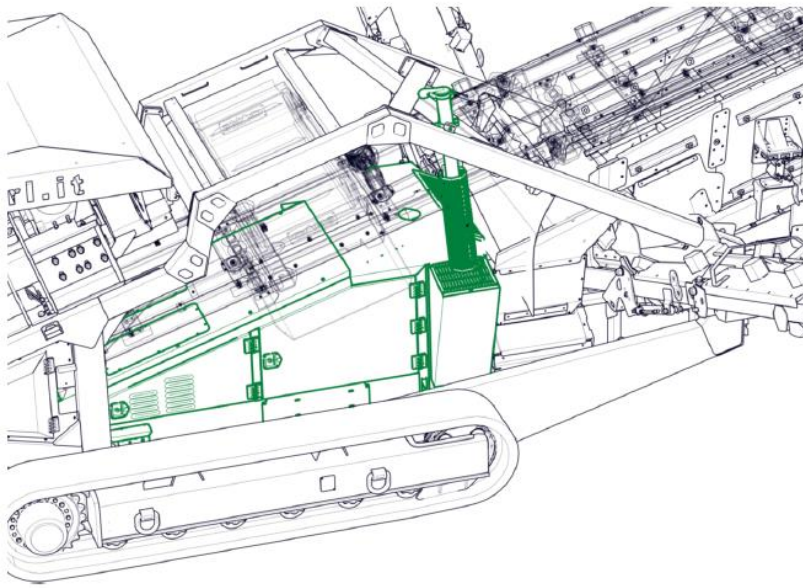

Genset:

Diesel Engine: IVECO C87 256 kW a 1500 rpm
 Alternator: M.E.C.C. ALTE 400 kVA

Tank capacities:

Hydraulic: | 85
 Fuel: | 220

Side Conveyors:

Belt width: mm 500
 Stockpile height: m 2.70÷ 3.30
 Electric moto-reducer: kW 5,5
 Hydraulically folding
 Dust reduction

Main Conveyor:

Belt width: mm 800
 Electric moto-reducer: kW 7.5
 Dust reduction

Tail Conveyor:

Belt width: mm 900
 Stockpile height: m 3.00÷ 3.70
 Electric moto-reducer: kW 5,5
 Hydraulically folding
 Dust reduction

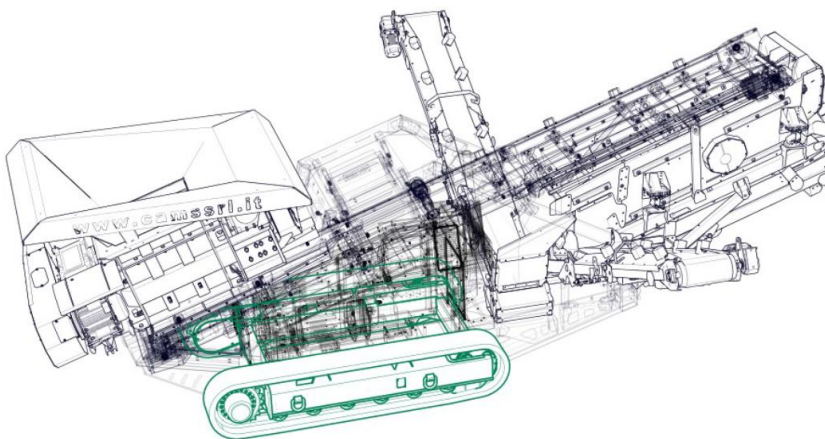
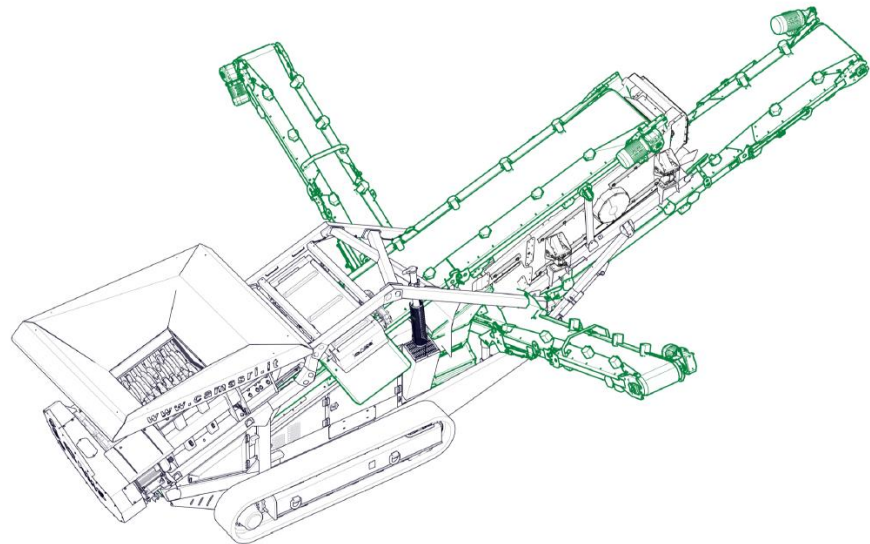

Track Data:

Track length: mm 3620
 Track width: mm 400
 Hydraulic Motor kayab: 86/50 cc
 Gearbox: Trasmital
 Speed: 0,2÷0,8 Km/h
 Control: Remote handset - Quadruple Speed

All specifications subject to change without prior notice

CAMS s.r.l.

**VIA Giulio Golini, 301 40024- Castel San Pietro Terme (BO)- Tel. 0516946611
 Cod. Fisc. e Part. IVA 02146431206- R.E.A. n° 416377- Cap. Soc. 93.000 euro Int. Vers.**



OPTIONAL EXTRAS

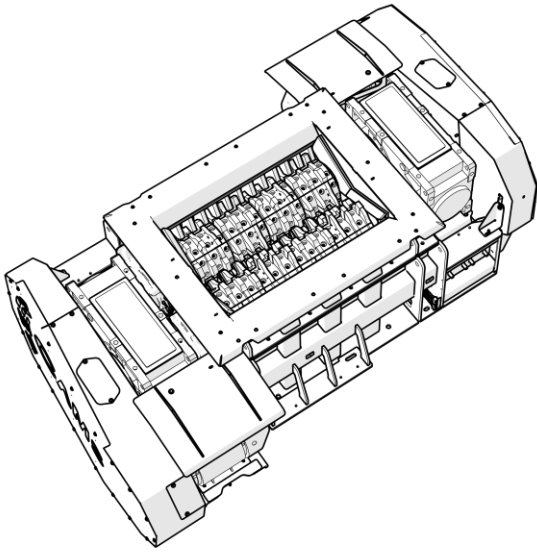

Shredder (Version for Asphalt):

Type of Shredder:	FTR 1200
Feed opening:	mm 1200x900
Number of armor plate:	pcs 48
Teeth height:	mm 60
Electric motors:	kW 60 (30+30)
Rotors speed:	rpm 10

Secondary Shredder:

Type:	CR 1200
Feed opening	mm 1200x700
Number of armor plate	n° 32 (16+16)
Teeth height:	mm 15
Electric motors:	kW 44 (22+22)
Rotors Speed:	rpm 20

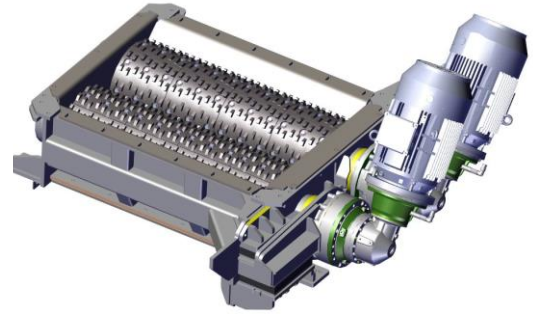
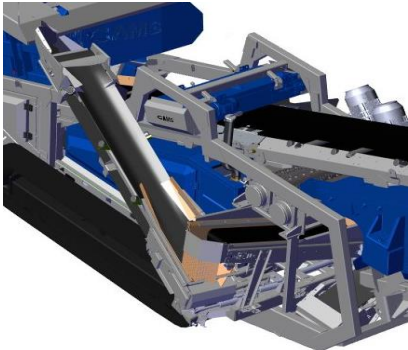

Recirculation Conveyor:

Belt Width:	mm 500
Belt Type:	chevron
Discharge Height:	m 2.85
Electric motor drum:	kW 4

Hydraulic Fingers:

Number of fingers	n° 5
Number of Knife:	n° 2/pcs.
Number of Teeth:	n° 2/pcs.

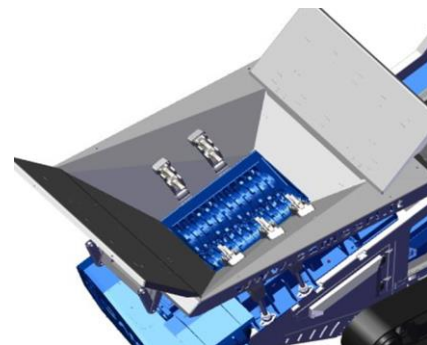
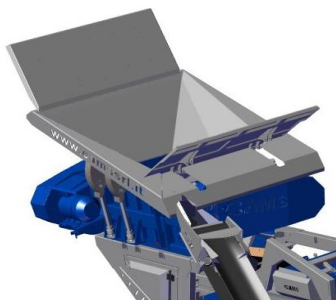

Hydraulic Feed Hopper extensions:

Height:	mm 800
Lenght	mm 750

All specifications subject to change without prior notice

CAMS s.r.l.

**VIA Giulio Golini, 301 40024- Castel San Pietro Terme (BO)- Tel. 0516946611
Cod. Fisc. e Part. IVA 02146431206- R.E.A. n° 416377- Cap. Soc. 93.000 euro Int. Vers.**



CENTAURO AT WORK

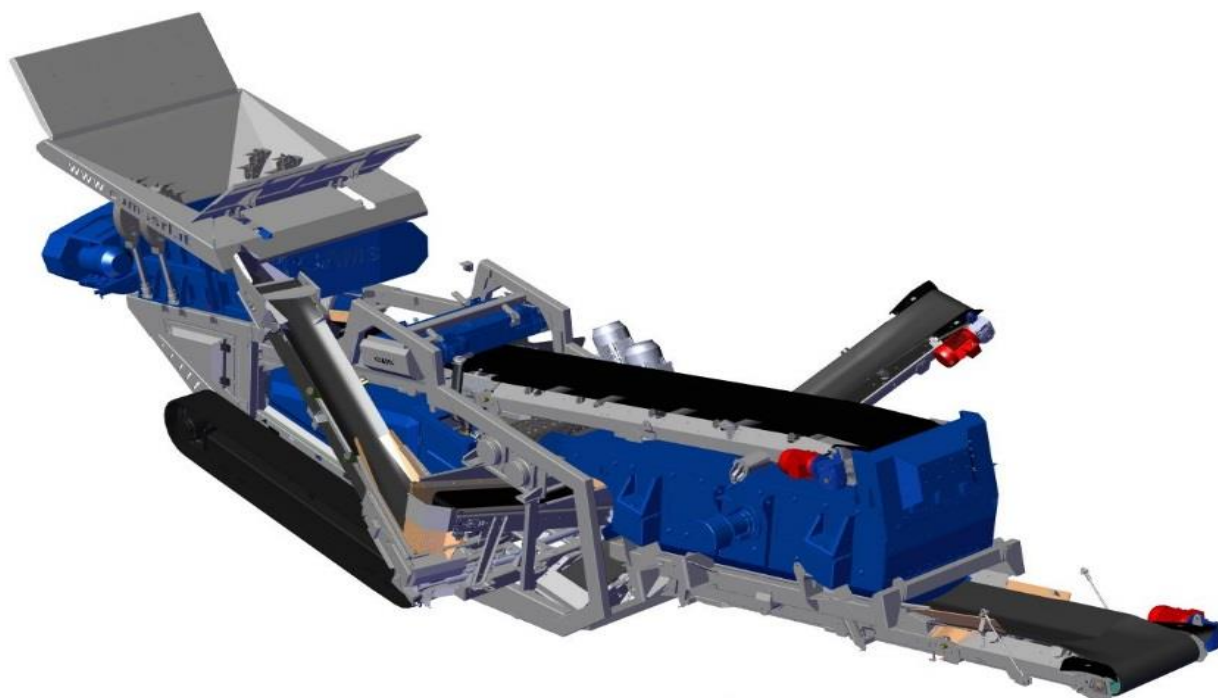

CENTAURO FOR SHIPPING

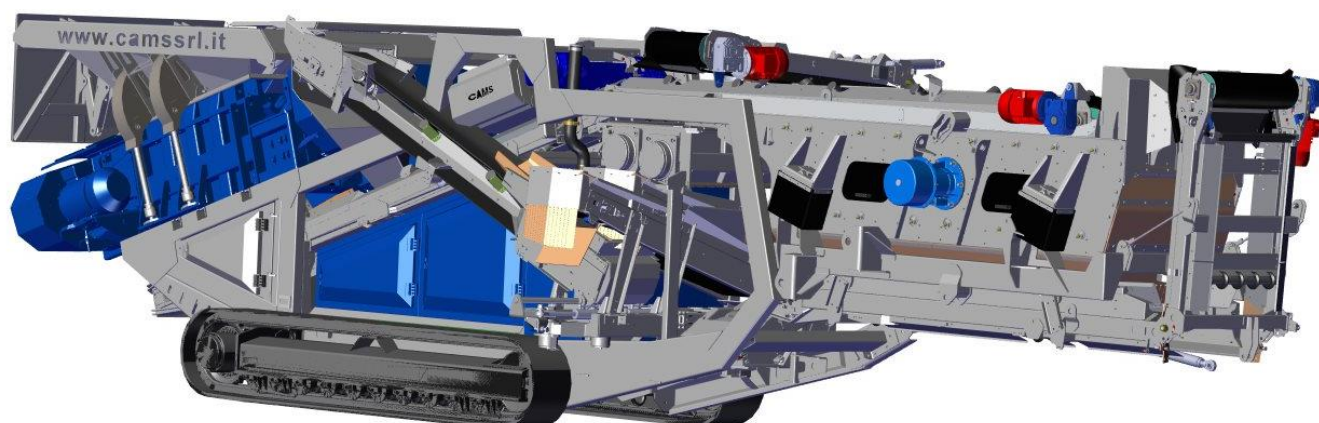

All specifications subject to change without prior notice

CAMS s.r.l.

**VIA Giulio Golini, 301 40024- Castel San Pietro Terme (BO)- Tel. 0516946611
Cod. Fisc. e Part. IVA 02146431206- R.E.A. n° 416377- Cap. Soc. 93.000 euro Int. Vers.**

