



K2R G1111CR | CVR



# K2 G1111C | CV



**K2**  
GI1111C | CV

**K2R**  
GI1111CR | CV

**SPECIFICHE  
TECNICHE**

**TECHNICAL  
SPECIFICATIONS**

**TECHNISCHE  
DATEN**

**CARACTERISTIQUES  
TECHNIQUES**

**MULINO A MARTELLI**  
IMPACT CRUSHER  
PRALLBRECHER  
CONCASSEURS À PERCUSSION

**TRAMOGGIA DI CARICO**  
FEED HOPPER  
AUFGABEBUNKER  
TRÉMIE ALIMENTATION

**ALIMENTATORE VIBRANTE  
A BARROTTI VERSIONE "C"**  
GRIZZLY FEEDER "C" VERSION  
STANGENVIBRATIONSAUFGEBER  
VERSION "C"  
SCALPEUR VIBRANT VERSION "C"

**VAGLIO VIBRANTE A 2 PIANI  
VERSIONE "CV"**  
DOUBLE DECK VIBRATING  
SCREEN "CV" VERSION  
ZWEI DECKEN VIBRATIONSSIEB  
VERSION "CV"  
CRIBLE VIBRANT A DEUX ÉTAGES  
VIBRANT VERSION "CV"

**PRODUZIONE MASSIMA**  
MAX PRODUCTION  
MAX LEISTUNG  
PRODUCTION

**PESO (SENZA OPTIONALS)**  
WEIGHT  
GEWICHT  
POIDS



**K2** = 2000 x 3970 mm. - 5 m<sup>3</sup>  
**K2R** = 2400 x 4570 mm - 6 m<sup>3</sup>

**K2** = 970 x 3600 mm  
**K2R** = 970 x 4000 mm

1020 x 2000 mm

360 Ton/h \*

**K2** = 37.000 Kg "C" - 37.500 Kg "CV"  
**K2R** = 47.000 Kg

**DIMENSIONI DI TRASPORTO**  
TRANSPORT DIMENSIONS  
TRANSPORTABMESSUNGEN  
DIMENSIONS DE TRANSPORT

**NASTRO TRASPORTATORE  
PRINCIPALE**  
MAIN BELT CONVEYOR  
HAUPTFÖRDERBAND  
TRANSPORTEUR PRINCIPAL

**CINGOLI**  
TRACKS  
RAUPENFAHRWERK  
CHENILLES

**IMPIANTO ABBATTIMENTO  
POLVERI**  
DUST SUPPRESSION SYSTEM  
STAUBABSAUGUNG  
ABATTAGE DE POUSSIÈRE

**POMPA TRAVASO GASOLIO**  
DIESEL TANK FILLING PUMP  
DIESEL ÖLBEHALTERFÜLLPUMPE  
POMPE DE REMPLISSAGE  
RÉSERVOIR DE GASOIL

**SEPARATORE MAGNETICO**  
MAGNETIC BAND SEPARATOR  
MAGNETABSCHIEDER  
SÉPARATEUR

**K2** = 13820 x 3400 x 2550 mm  
**K2R** = 17060 x 3600 x 3000 mm

1000 x 11250 mm

450 x 3800 mm

**K2R SISTEMA DI RICIRCOLO**

Vaglio vibrante ad un piano  
1500 x 3500 mm.  
Nastro trasportatore estrattore  
sopra vaglio  
Nastro trasportatore sotto vaglio  
Nastro trasportatore brandeggiante  
di ricircolo

**K2R RE-CIRCULATING SCREENING  
SYSTEM**

Single deck vibrating screen  
1500 x 3500 mm.

Side transfert conveyor  
Collection conveyor  
Re-circulating conveyor

**K2R KREISLAUFSYSTEM**

Ein Deck Siebmaschine  
1500 x 3500 mm.  
Austragförderband oben Siebmaschine  
Förderband unter Siebmaschine  
Schwenkbar förderband für Kreislauf  
Rückführung

**K2R SYSTÈME DE RECIRCULATION**

Crible vibrant à un étage  
1500 x 3500 mm.  
Convoyeur à bande dessus crible vibrant  
Convoyeur à bande sous crible vibrant  
Convoyeur à bande pivotant  
de recirculation

**OPTIONAL**

**RADIOCOMANDO LIV.1 - LIV.2**  
RADIO REMOTE CONTROL  
FERNSTEUERUNG  
COMMANDE À DISTANCE

**NASTRO LATERALE**  
SIDE BELT CONVEYOR  
SEITENAUSTRAGSFÖRDERER  
BANDE TRANSPORTEUSE LATÉRALE  
**600 x 4500 mm**

**POMPA PER IMPIANTO  
ABBATTIMENTO POLVERI**  
WATER PUMP FOR DUST  
SUPPRESSION SYSTEM  
SELBSTANLASSENDE PUMPE  
FÜR STAUBABSAUGUNG  
POMPE POUR INSTALLATION  
D' ABATTAGE DE POUSSIÈRE

\* La produzione massima dipende dal tipo di materiale trattato e dal settaggio del mulino

\* The production depends of the material treatment and the C.S.S..

**K2**

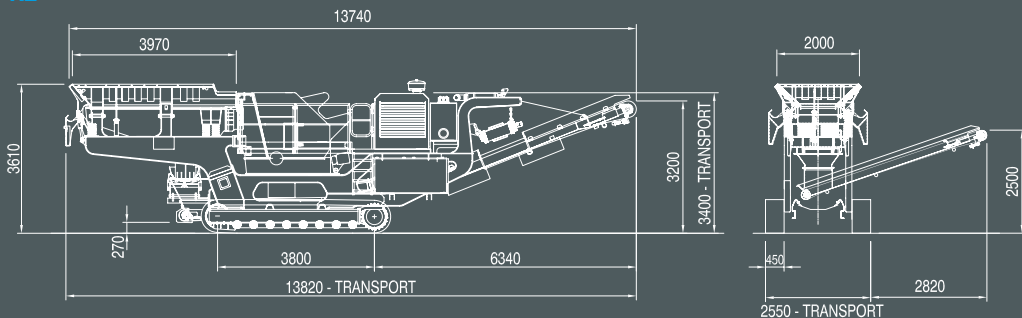

**K2R**

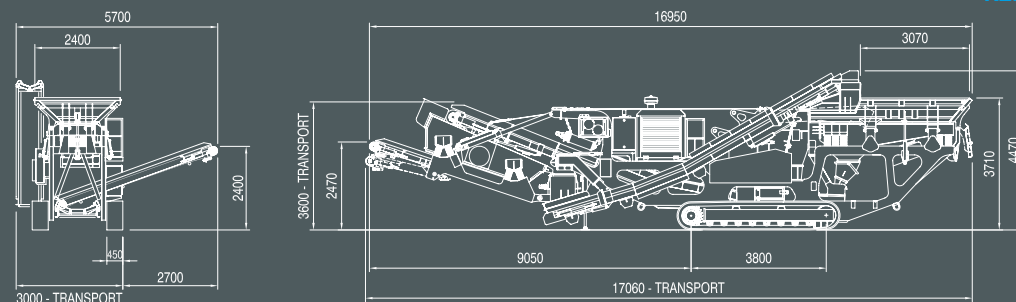

Via Giorgione, 17 - S.S. Feltrina  
T +39 0423 670201  
F +39 0423 676575

[www.gasparin-omg.com](http://www.gasparin-omg.com)  
[info@gasparin-omg.com](mailto:info@gasparin-omg.com)

LOCAL UNIT  
Via Palladio, 29  
T +39 0423 670001  
F +39 0423 670602  
31040 Musano di Trevignano  
(Trevise) Italy



YOUR PARTNER IN CRUSHING & SCREENING

